

WINE MASTER®

———— le temps d'être différent



Wine IN50+

Installation and operation manual

INDICATIONS PLACED ON THE NAMEPLATE FOUND ON THE APPLIANCE :

- Model :
- Serial number :
- Purchase date :

IMPORTANT :

IT IS RECOMMENDED TO NOTE THE SERIAL NUMBER AND TO WRITE IT DOWN IN THE BOX ABOVE. IT WILL BE NECESSARY FOR ORDERING SPARE PARTS

Réf : W5086

11/2011



User manual

Table of contents

1. CELLAR EQUIPMENT	5
1.1. Evacuation room	5
1.2. Cellar insulation	6
1.2.1. Insulation of walls, ceiling and floor	7
1.2.2. The door	8
1.2.3. Insulation of other elements	8
2. INSTALLATION OF WINE CONDITIONNING UNIT WINEMASTER®	9
2.1. Installation of ducting connection	10
2.1.1. Ducting Kit composition.....	10
2.1.2. Examples	11
2.1.3. Preparation.....	11
2.1.4. Wall drilling	12
2.1.5. Air conditioner's installation	12
2.1.6. Grids installation	13
2.2. Installing the water drainage system	14
3. USING THE WINE CONDITIONNING UNIT WINEMASTER®	15
3.1. Connecting the air conditioner WINE IN50+.....	15
3.2. Plugging in the wine conditioning unit WINE IN50+	16
3.2.1. Temperature setting of the air conditioner unit WINE IN50+	16
3.3. Standby mode	16
3.4. Automatic defrost.....	16
4. MAINTENANCE OF THE AIR CONDITIONNER WINEMASTER®	17
4.1. Replacing the filter	17
4.2. Thermostat wiring	17
5. WARRANTY	18
5.1. Legal Warranty	18
5.2. 2 years contractual warranty	18
5.3. Warranty conditions	18
5.4. Exclusions and limitations of warranty	18

Introduction

You purchased an air conditioner WINEMASTER® and we thank you for your confidence.

From conception to commercialisation, everything has been implemented to offer an exclusive and high quality product. Brainchild of a team who find in this a motivation to ever give satisfy you, we hope that your wine conditioning unit WINEMASTER® will bring you great storage and best wines aging for an incomparable pleasure.

Because the customer is at the heart of all our thoughts, we want to support you in your first steps and lead you towards the best use of your air conditioner every day. Thus, you will find in this manual technical information and practical advice to help you to deal with the essential steps to installation and use.

In order that your wine tasting remains moments to share, FONDIS guarantees you a sincere engagement, dedicated expertise and ongoing follow-up at your service!

FONDIS.



Technicals Datas

	WINE IN50+
Weight	52.6 kg
Dimensions	H.1044 X L.500 X P.428
Temperature setting	Preset to 12°C, adjustable between 4 et 15°C *
Maximum outside temperature	35°C **
Cooling power	1200 W à 15°C **
⚡ Electric supply	230/240V-50 Hz + 3 m cable
❄ Electric power	550 W
☀ Heating power	500 W
Pression	900-1100hPa

The circuit breaker must be at least **16 Amps**.

* The insulation quality and thickness has to be in accordance with the volume of the cellar and the set temperature.

** The cooling performance is dependant from the outside temperature. Therefore, the set temperature of 12°C for the cellar cannot be maintained if the outside temperature reaches the 35°C.

If the thermal safety functions to often, there is a risk for the compressor to be damaged. In all cases, it must be avoid that the outside **temperature remains at 35°C**, this high temperature should be limited to the summer period.

Technical Drawings

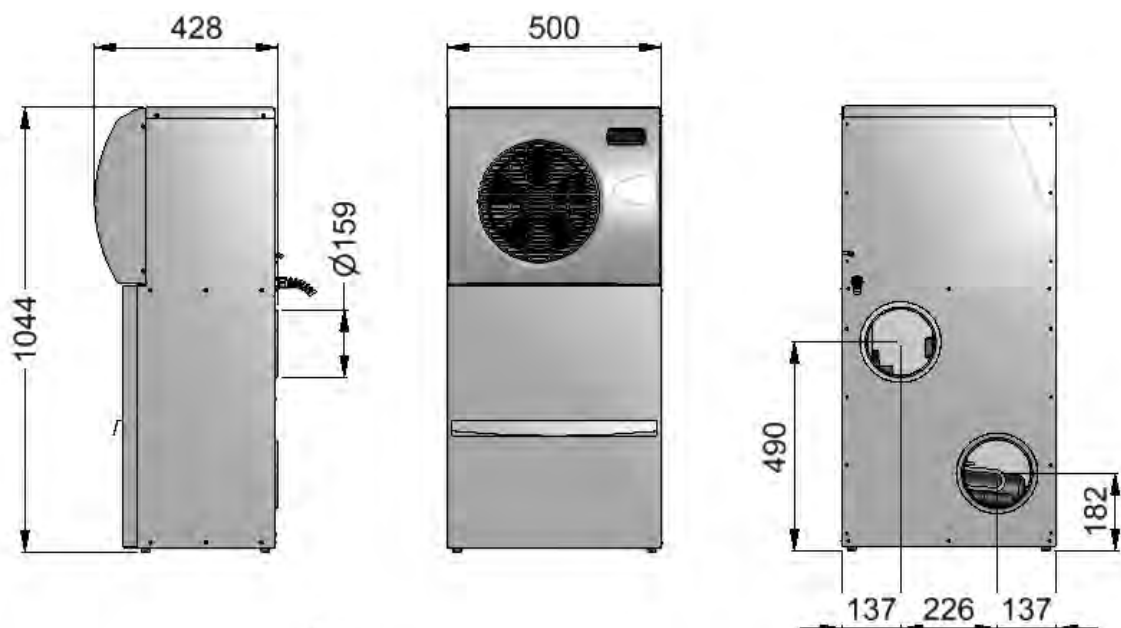

1. CELLAR EQUIPMENT

The air conditioner has to be installed in the wine cellar on the supplied horizontal supports adapted to the weight of the unit.

For a correct functioning, the unit expels air at the outside to 15°C above the temperature of the air inlet aspiration. This air must be cooled in a well ventilated room or be evacuated outside.

→ **This operation will be done thanks to the insulated ducts in the inside of the cellar**

1.1. Evacuation room

If WINEMASTER® evacuates hot air inside the room you have to **ventilate the room** :

- Maximum temperature and non permanent $\leq 35^{\circ}\text{C}$
- Ideal temperature $\approx 20^{\circ}\text{C}$.

→ **It is recommended to evacuate the hot air to the outside with ducts if possible.**

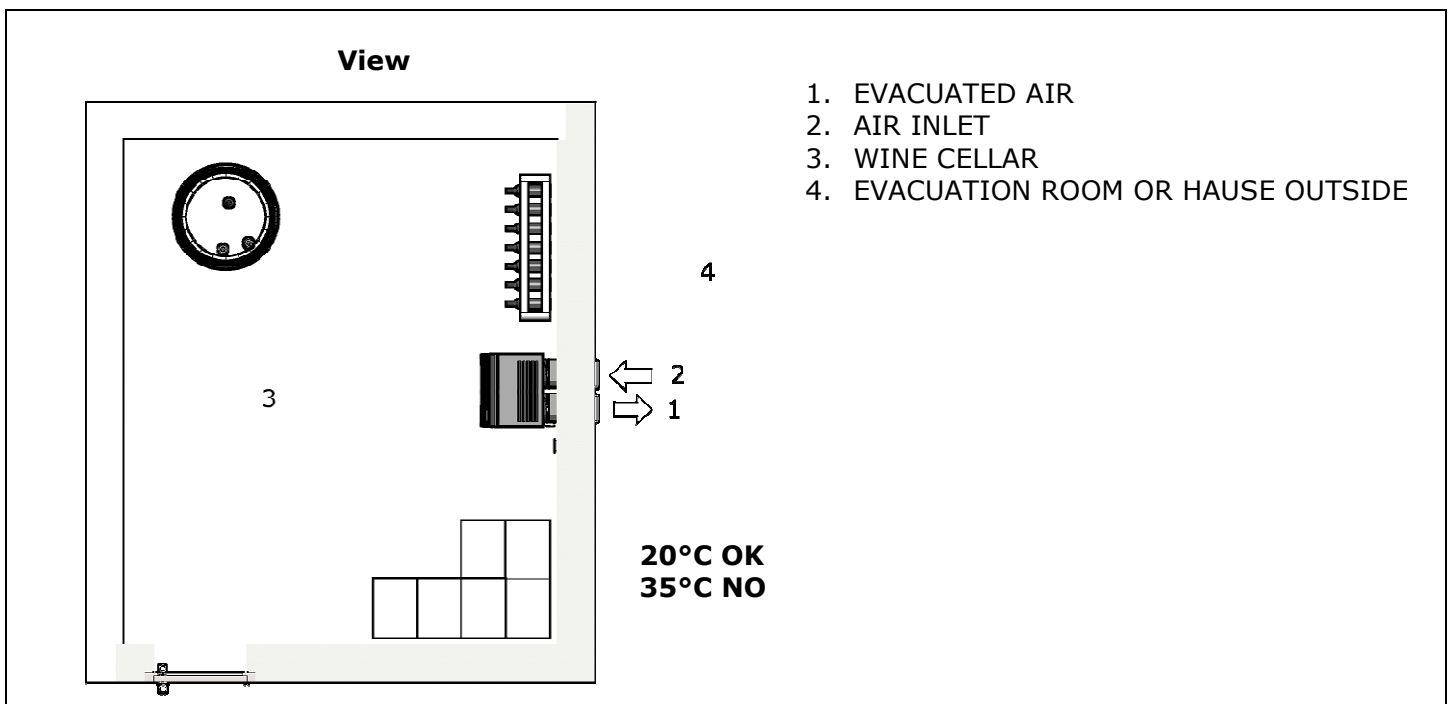
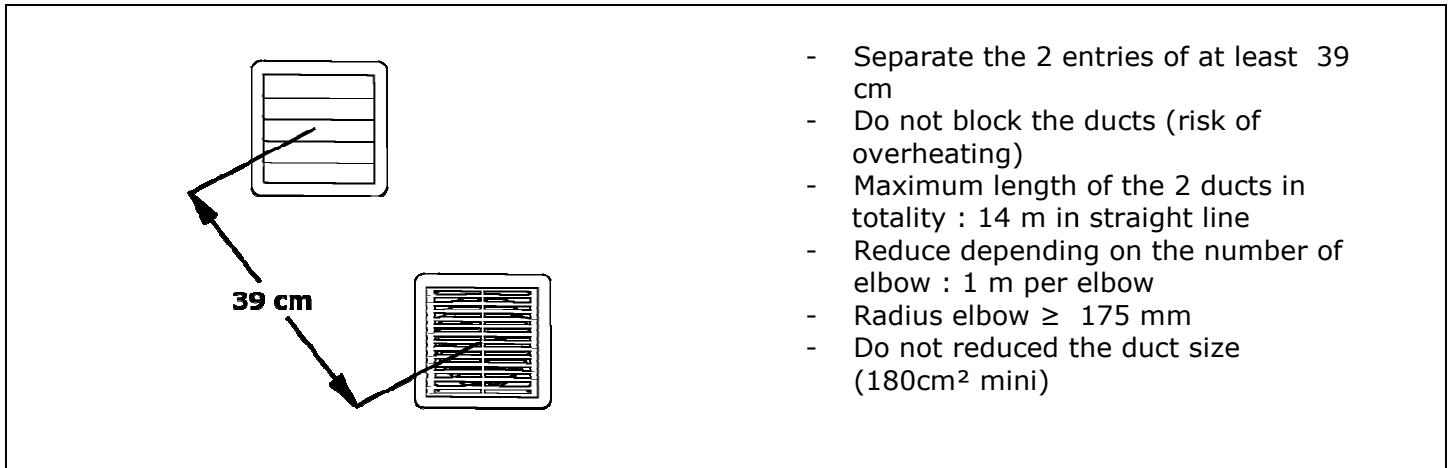

LE FROID VENTILE OU « NO FROST »

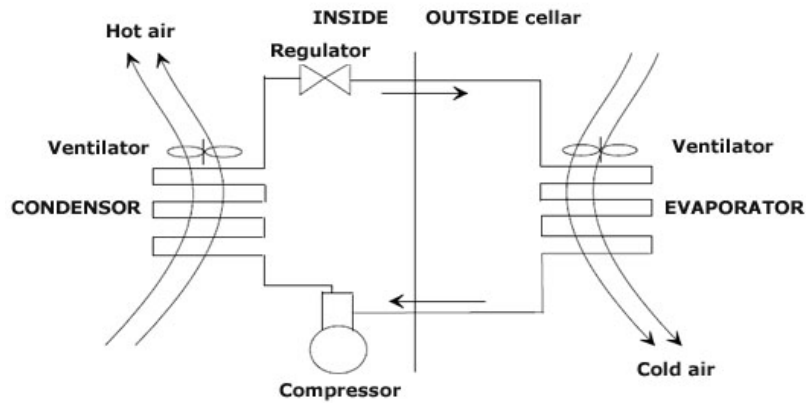

The advantages of « ventilated cold »:

- No frost other than on the evaporator.
- Automatic defrosting and maximized refrigeration efficiency.
- Cold distribution improved by a permanent air circulation (without air stratification).
- The circulation of air allows maintaining the pre-selected temperature throughout the cellar.

1.2. Cellar insulation

Insulation is essential for efficient functioning of the WINEMASTER®. A good insulation enables to maintain a stable **temperature and humidity level**. The chart on the next page will allow you to determine the type and thickness of insulation needed in relation to the exterior volume of the cellar and model of the WINEMASTER®, for an inside temperature of 12°C.

Complete insulation

The insulating elements should be preferably :

- By « tongue and groove » panels or
- By panels fused together

→ **IMPORTANT: Avoid the intrusion of heat and humidity which can alter the functioning of the WINEMASTER®.**

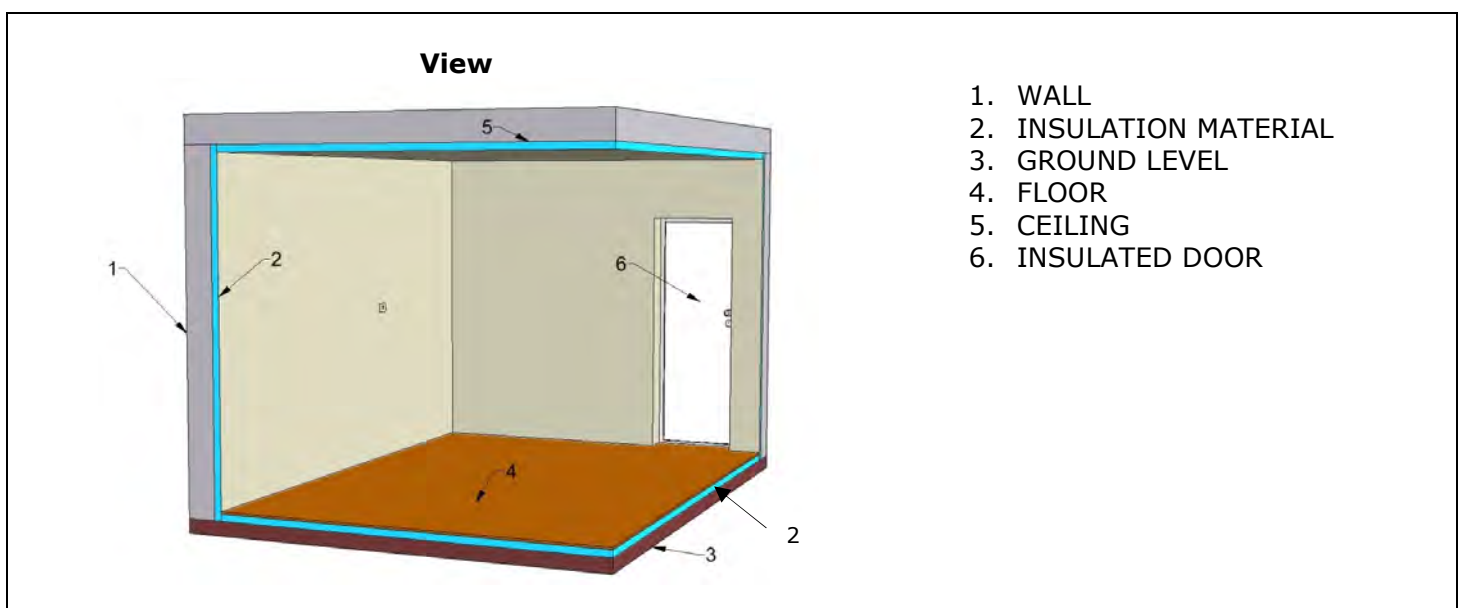

1. WALL
2. INSULATION MATERIAL
3. GROUND LEVEL
4. FLOOR
5. CEILING
6. INSULATED DOOR

IMPORTANT

The WINEMASTER® warranty is only valid if the insulation is in compliance with the board « Insulation selection » requirements for the whole cellar (walls, floor, door and ceiling) with perfect continuity of insulation.

Insulation selection

MINIMAL THICKNESS OF INSULATION (mm)				
VOLUME OF THE CELLAR (m ³)	MINIMAL THERMAL RESISTANCE R : m ² . °C/W	Polystyrene expanded $\lambda = 0.044\text{W/m } ^\circ\text{C}$	PPolystyrene extruded $\lambda = 0.030\text{W/m } ^\circ\text{C}$	Polyurethane foam $\lambda = 0.025\text{W/m } ^\circ\text{C}$
14	0,94	50	30	30
16	1,08	50	40	30
18	1,21	60	40	40
20	1,35	60	40	40
22	1,48	70	50	40
24	1,62	80	50	50
26	1,75	80	60	50
28	1,88	90	60	50
30	2,02	90	60	60
32	2,15	100	70	60
34	2,29	110	70	60
36	2,42	110	80	70
38	2,56	120	80	70
40	2,69	120	90	70
42	2,82	130	90	80
46	2,96	130	90	80
50	3,23	150	100	80

1.2.1. Insulation of walls, ceiling and floor

Type of insulation panels

You can select among the following type of panels :

- Usual panels,
- « Complex panels »: insulation is covered with a with a cover material (plaster, mineral
- « Sandwich panels »: insulation is covered on each side with a wooden panel or plaster board.

Important : The covering of the panels **protects the insulation against damage and guarantees its longevity. Avoid using mineral fibres insulation** (glass wool, rock wool, etc...) as they may accumulate moisture and lose their insulation power and avoid also thin film insulation that are not effective for cold.

DO YOU KNOW THAT ?

Some insulating materials are damaged by rodents. If necessary, cover the insulation with a protective lining on the inside of the cellar to avoid presence of mouse or rats.

→ **Polyurethane is an insulator that, due to its chemical composition, is not attacked by the rodents**

Floor insulation

The floor of the cellar must be able to support the shelves and the stored wine. Thus, it's necessary to choose insulation with adequate compression strength.

Improve the load capacity of the insulation (particularly under the shelf legs) by using :

- « **Complex** » insulation panels covered by panels of higher load capacity.
- **Cover the insulation panel with a wooden panel** (at least 15 mm thickness), or every other appropriated material.

1.2.2. The door

Door improves the insulation. Two solutions are possible :

- **Insulate an existing door with the same insulation materials used for the walls of the cellar.** Provide a tight seal between the door frame and all sides of the door with a strip of foam rubber for example.
- **Use a specially design FONDIS isothermal door** with polyurethane and a sealing foam rubber.

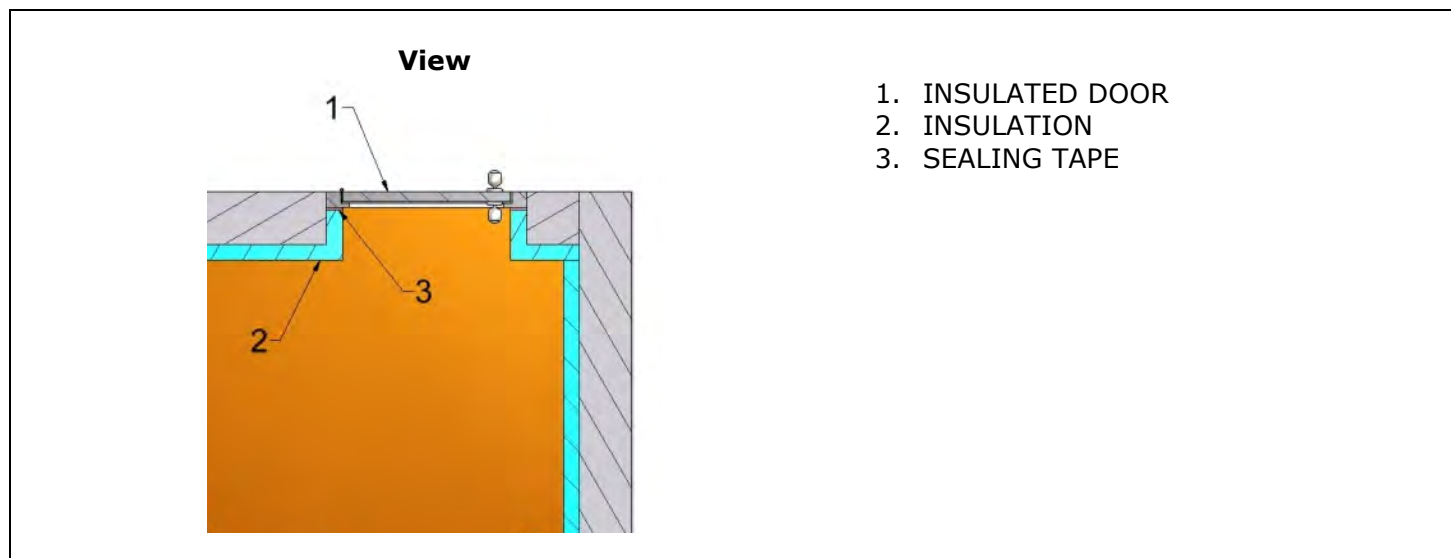

1.2.3. Insulation of other elements

Avoid placing a wine cabinet or freezer who generates heat in the cellar. **The central heating pipes should be re-insulated** during their passage through the cellar.

2. INSTALLATION OF WINE CONDITIONING UNIT WINEMASTER®



THE UNIT HAS TO BE INSTALLED RESPECTING THE NATIONAL RULES OF ELECTRIC INSTALLATIONS.

Make sure to choose the correct location for the air conditioner :

- Choose the perfect location : length of duct as short as possible,
- No obstacle in front of ventilation (helps flow of cold air moving),
- Level the supports in order to avoid vibrations,

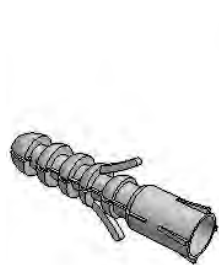
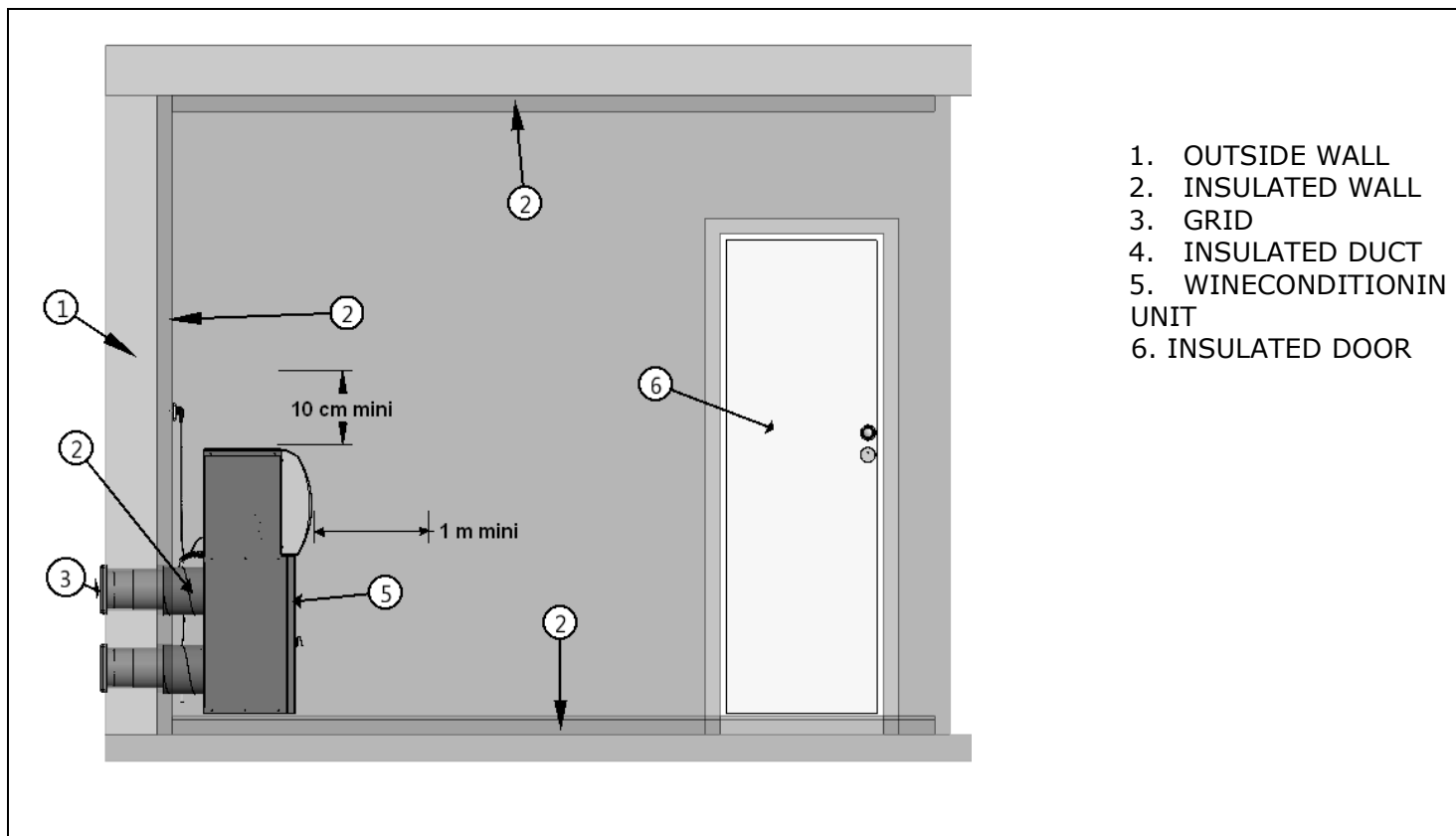

X 8



X 8

Necessary material (not delivered) in order to fix the grids



Material included in the box

2.1. Ducting Kit installation

2.1.1. Composition of the ducting kit

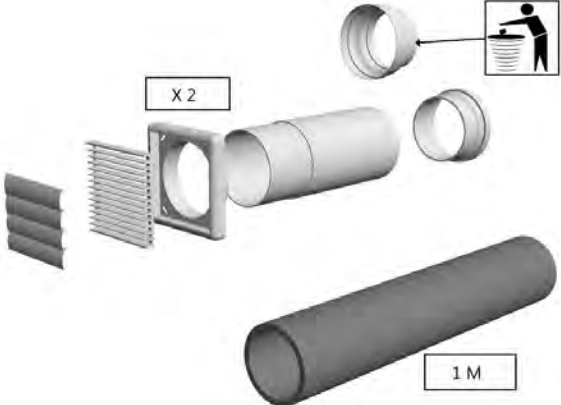
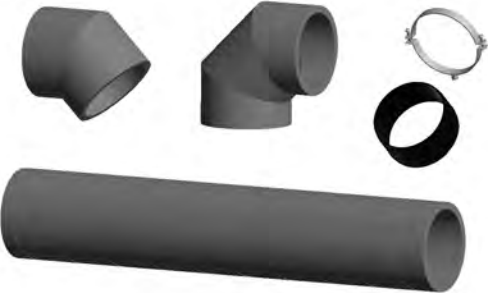
	<p>Composition of the basic kit</p> <ul style="list-style-type: none">- 2 grids kit with telescopic sleeve- (reduction Ø125 non used)- 1 meter isolated straight pipe Ø 160
	<p>Possibility of ordering additional parts</p> <ul style="list-style-type: none">• 2 meter isolated straight pipe Ø 160 with muff• Elbow 90° with muff• Elbow 45° with muff• Collars

2.1.2. Examples

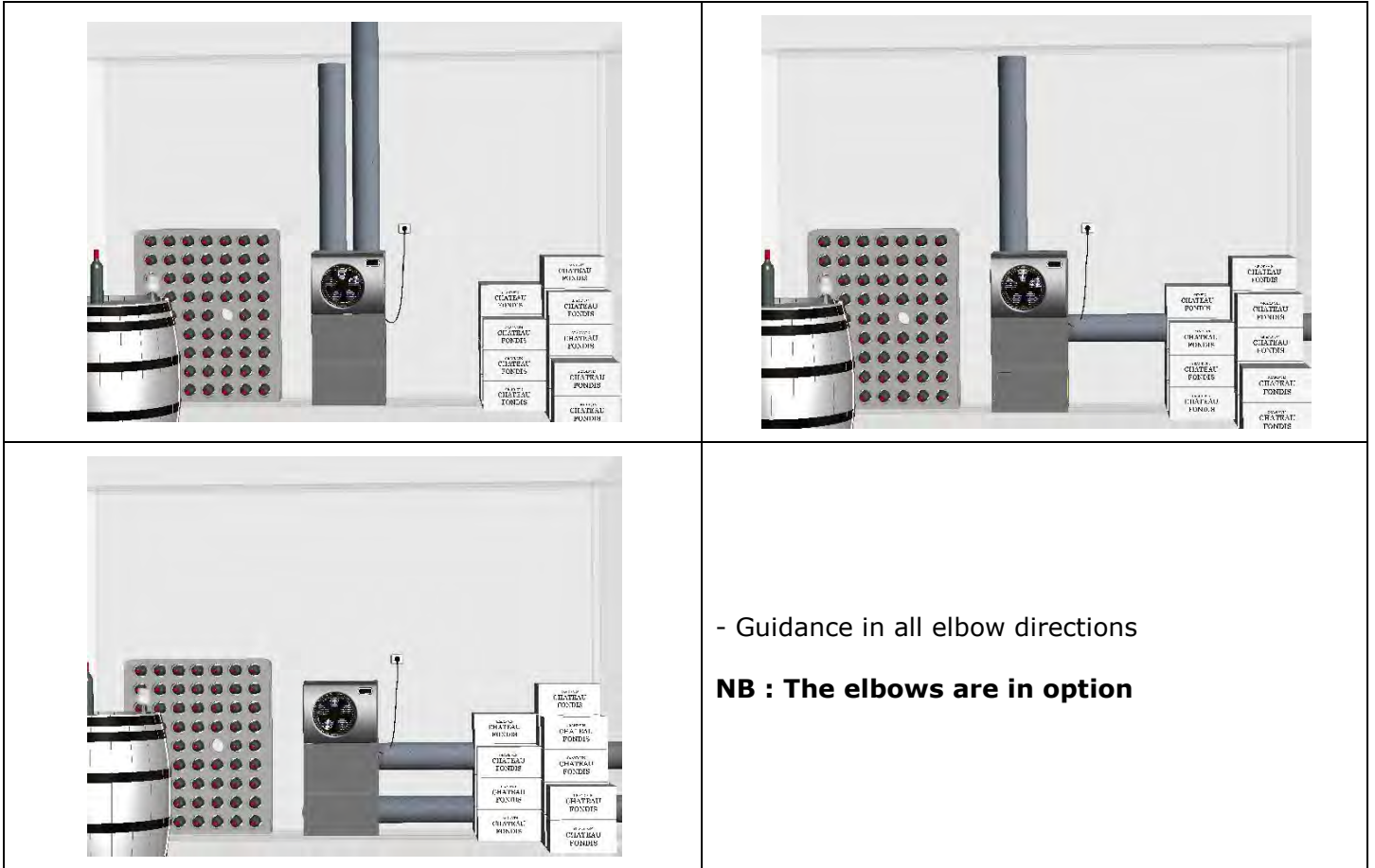

2.1.3. Preparation

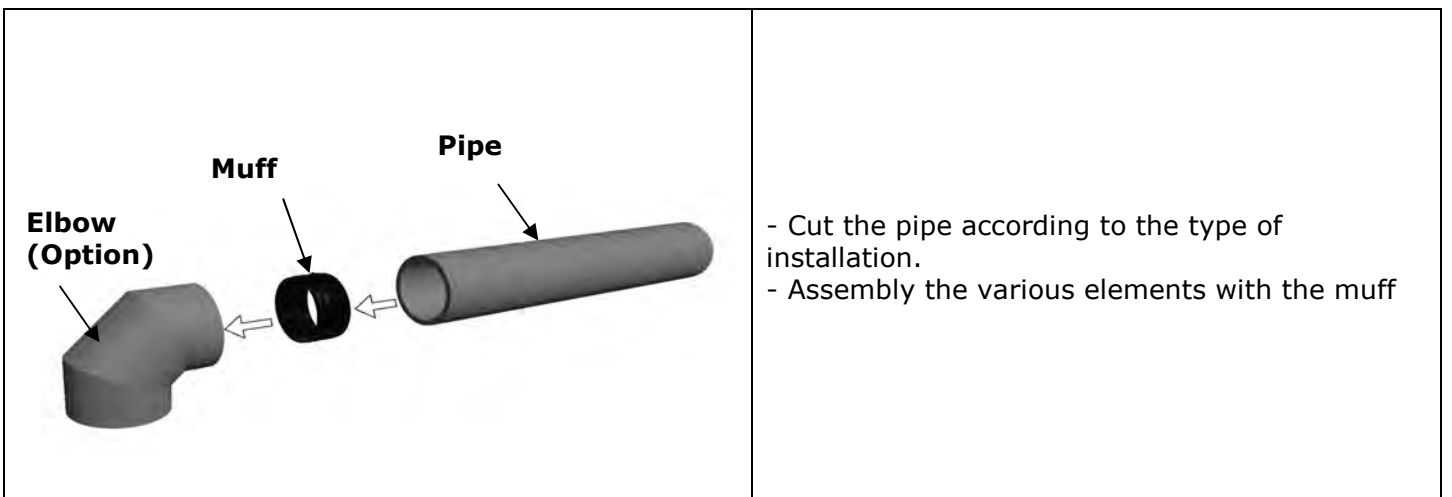

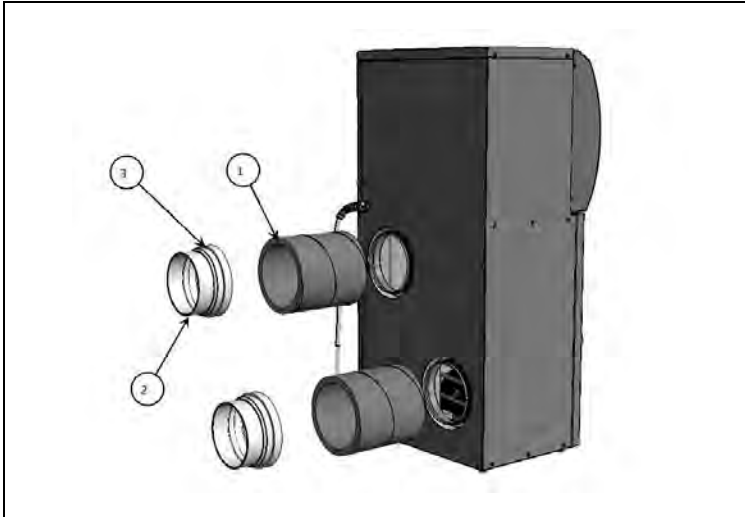

- Fix the air-conditioner on to the isolated pipes.
- There is no collar, the pipes are equipped with lip seals
- put the reduction with the gasket at the other end of pipe

2.1.4. Wall drilling

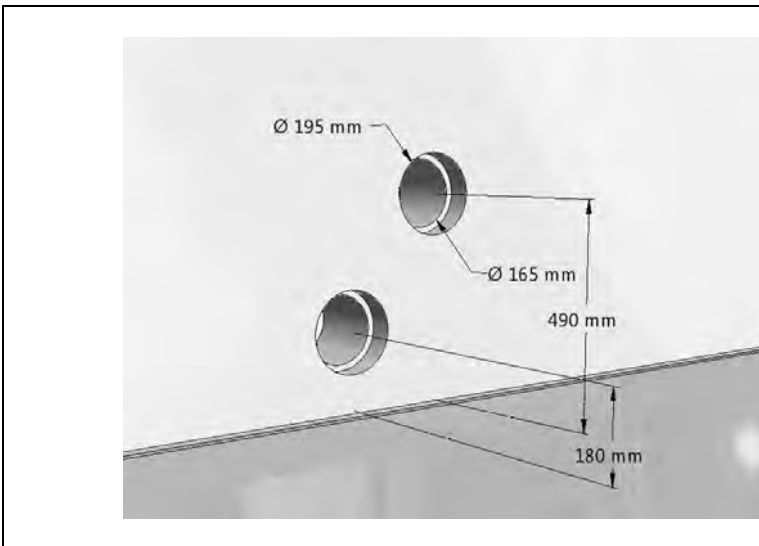

- Drill 2 holes diam 165 through the wall to pass the telescopic sleeves.
- Increase the diameter to 195mm in the insulation material to integrate the reduction

2.1.5. Air conditioner installation

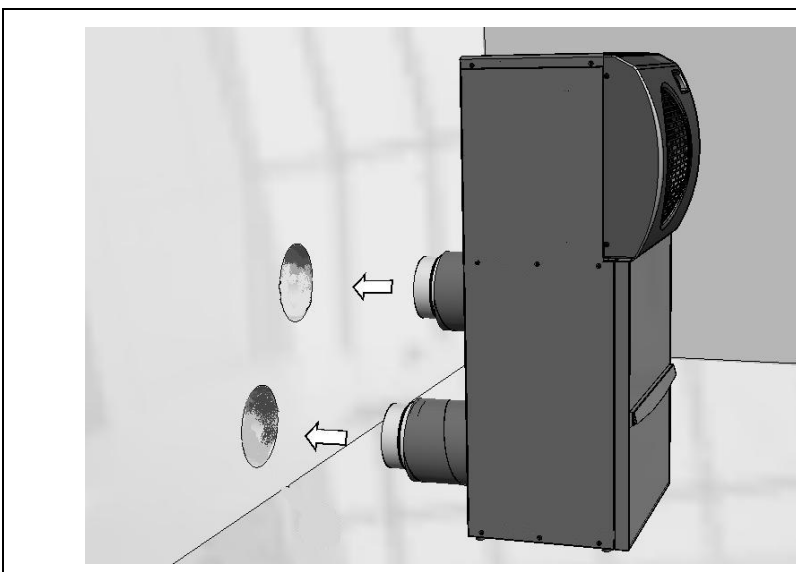

- place the air-conditioner at the site wanted while making pass the sheath through the hole in the insulation

2.1.6. Installation of the grids

ASSEMBLY DETAILS

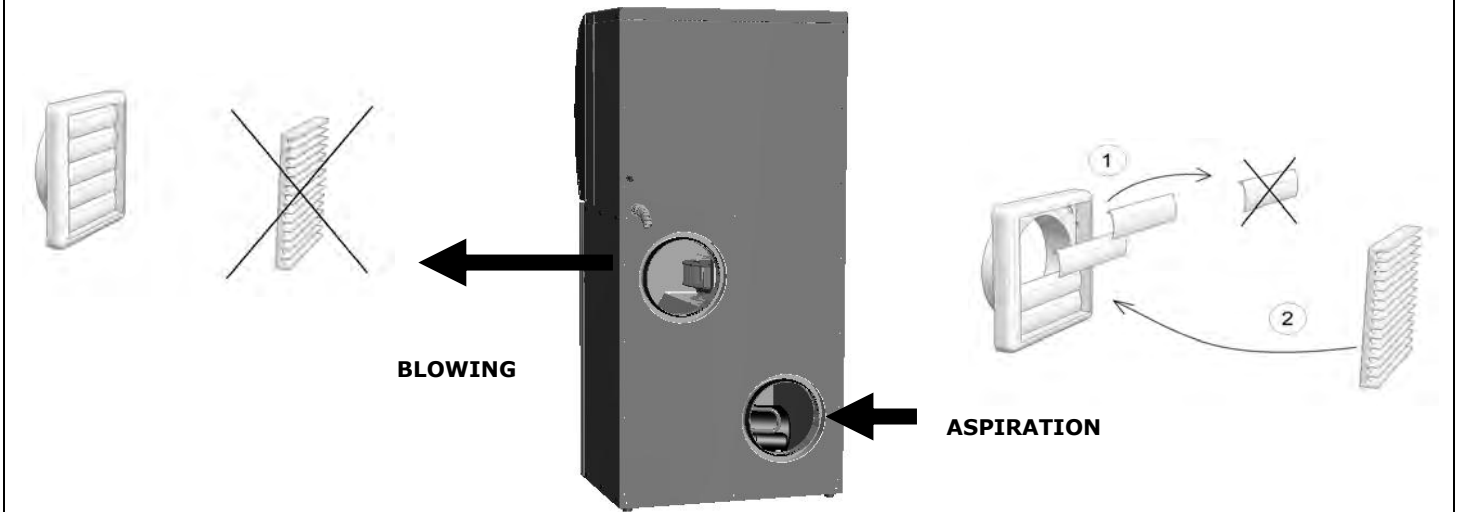

ATTENTION ! each case is composed of 2 grids (blowing and aspiration). it is necessary to adapt the type of grid

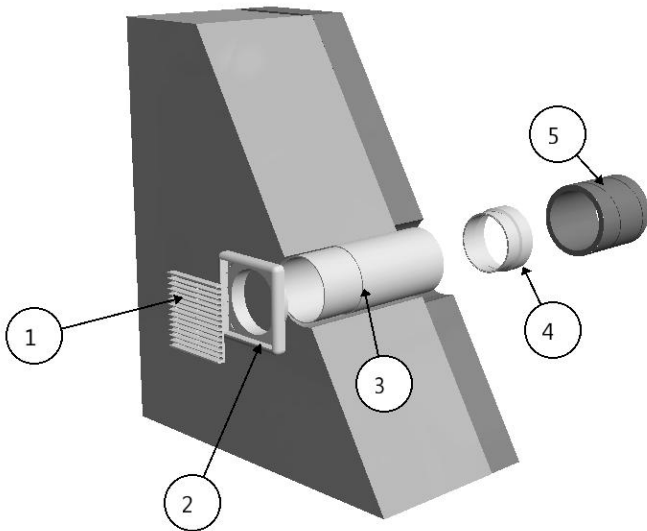

1. Grids
2. Frame
3. Telescopic sleeve
4. Reduction
5. Insulated pipe

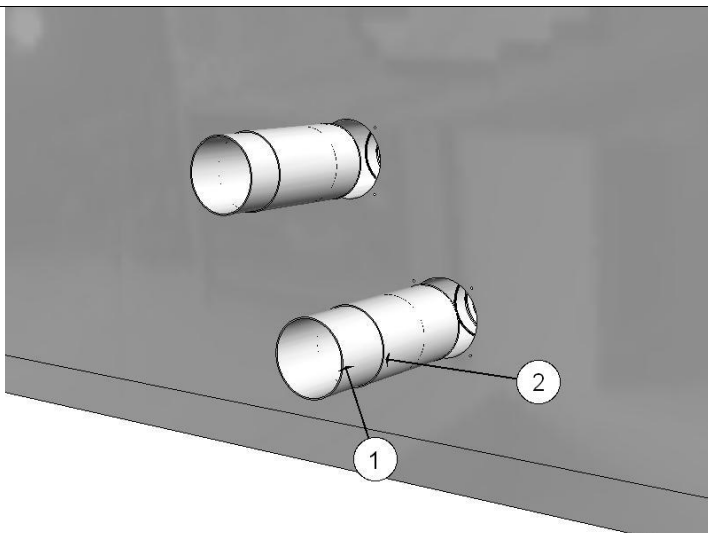

- Connect the 2 pipes on the reduction
- fill the vacuum between the telescopic sleeve and the hole of the wall thanks to insulating material. (Polyuréthane foam)

1. Sleeve small part
2. Sleeve great part

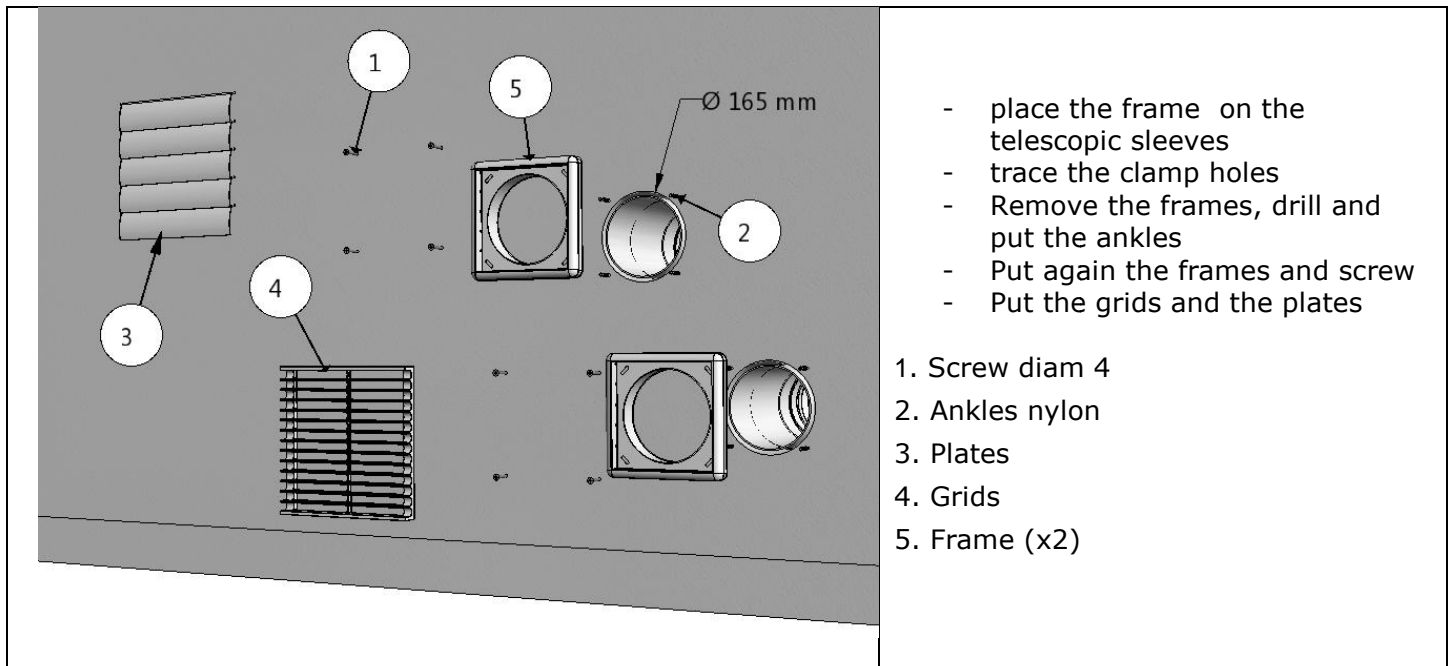

2.2 Installing the water drainage system and alimentation cable



If the electric cable is damaged, it must be replaced by manufacturer, by his after sales service or similar qualified person in order to avoid a danger.

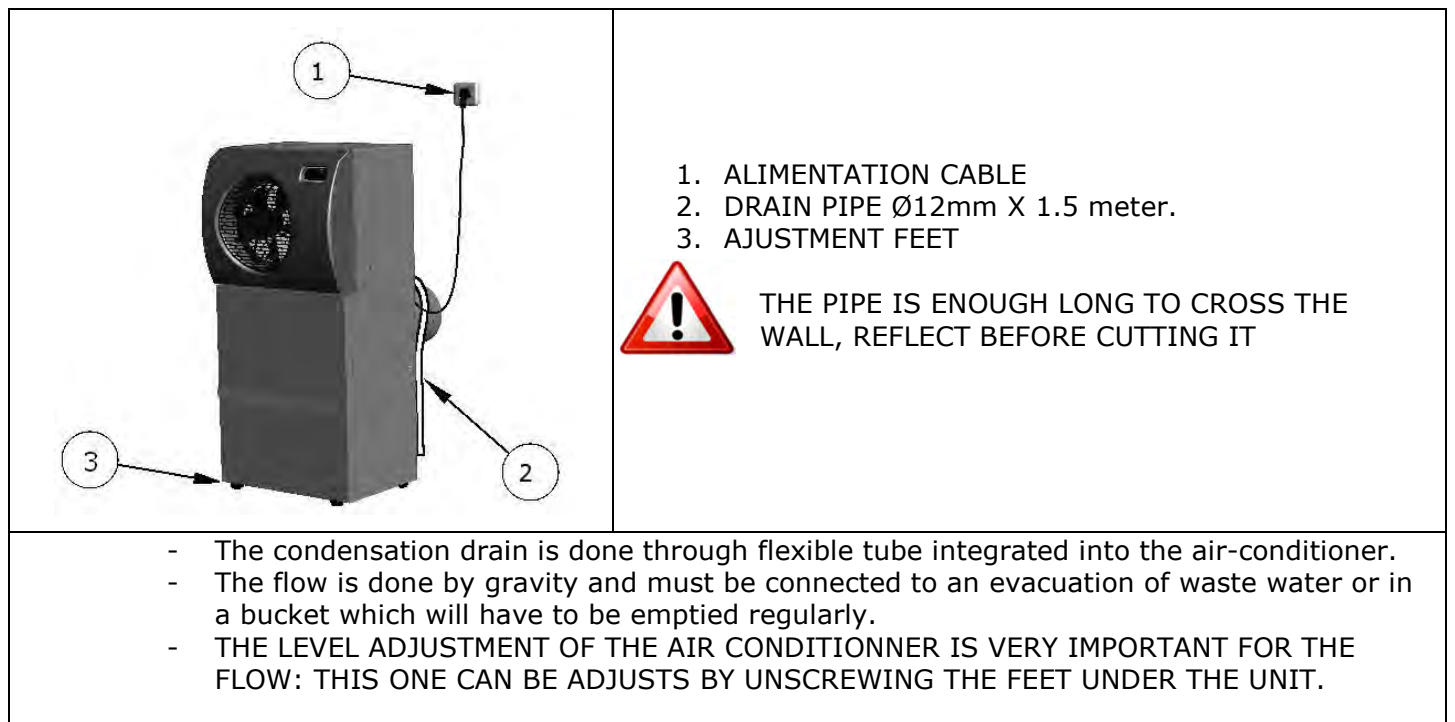

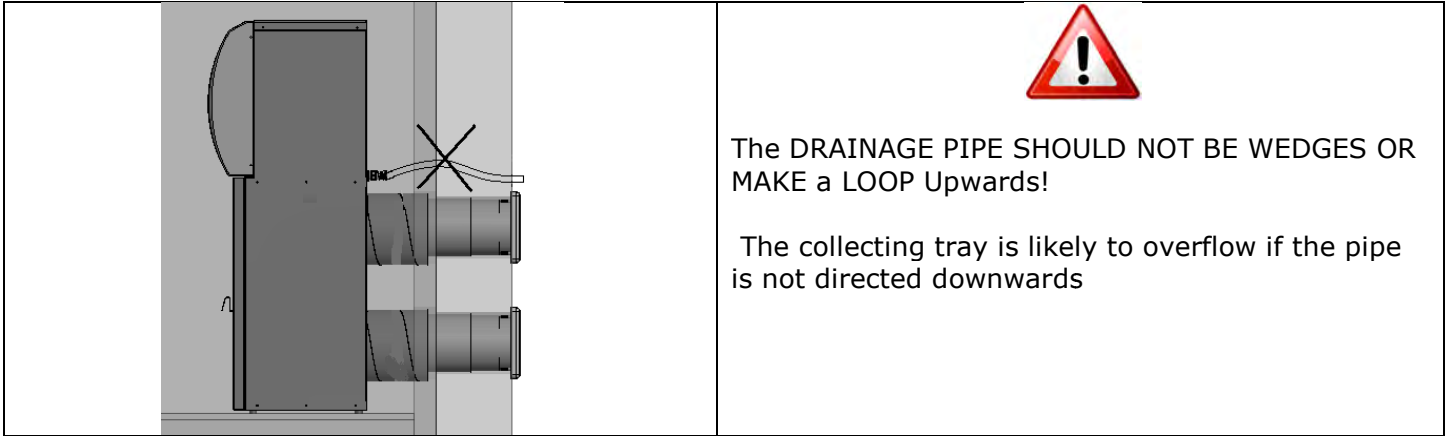

↩ Important :
After transport or maintenance, wait for 24 hours before switching on the air conditioner.

3. USING THE WINE CONDITIONNING UNIT WINEMASTER®

The thermostat indicates the temperature in the wine cellar with a precision of 2°C. A temperature change of the air doesn't mean the same change of temperature of the liquid due to the thermal capacity of the liquid. The temperature is set at 12°C in the factory. During installation the set temperature must be controlled and adjusted as shown in next paragraph if necessary.

3.1. Connecting the air conditioner WINE IN50+

When you plug the unit to the electrical socket, the display indicates the temperature of the cellar :

- If the cellar temperature \geq to the thermostat setting : the fan starts up immediately
- If the cellar temperature \leq to the thermostat setting : the fan doesn't start. Only the ventilator works.







The power outlet must be accessible after installation.

3.2. Plugging in the wine conditioning unit WINE IN50+

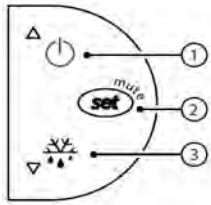
3.2.1. Temperature setting of the air conditioner WINE IN50+

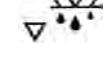

The setting of the targeted temperature is made on the thermostat :

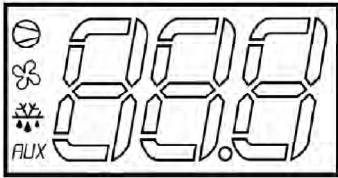

- Press button  one second until the targeted temperature is blinking.
- Use button  to increase the temperature or
- Use button  to lower the temperature.
- When the right temperature is set, press again on button  to confirm it.

Explanation of the main display symbols :



- Red light  = cold mode engaged (compressor working)
- Red light  = cooling fan high speed
- Red light  = defrost
- Red light *AUX* = heat mode engaged (resistance)

3.3. Standby mode

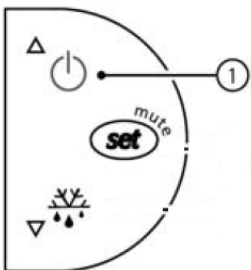

- Standby mode : maintain a 3 seconds pressure on button 1. The compressor stops and the fan turn at low speed.
- The thermostat indicates « OFF » and also the cellar temperature.
- To come back, maintain again a 3 seconds pressure on button 1.
- The thermostat indicates « ON » during 1 second.

3.4. Automatic defrost

- The program of the IN50+ thermostat will run an automatic defrost time several times a day. During this operation, the compressor is stopped, only the fan is functioning at low speed. The condensate water producing during this period will be evacuated through the tube drain.

5. MAINTENANCE OF THE AIRCONDITIONER WINEMASTER®

5.1. Replacing the filter

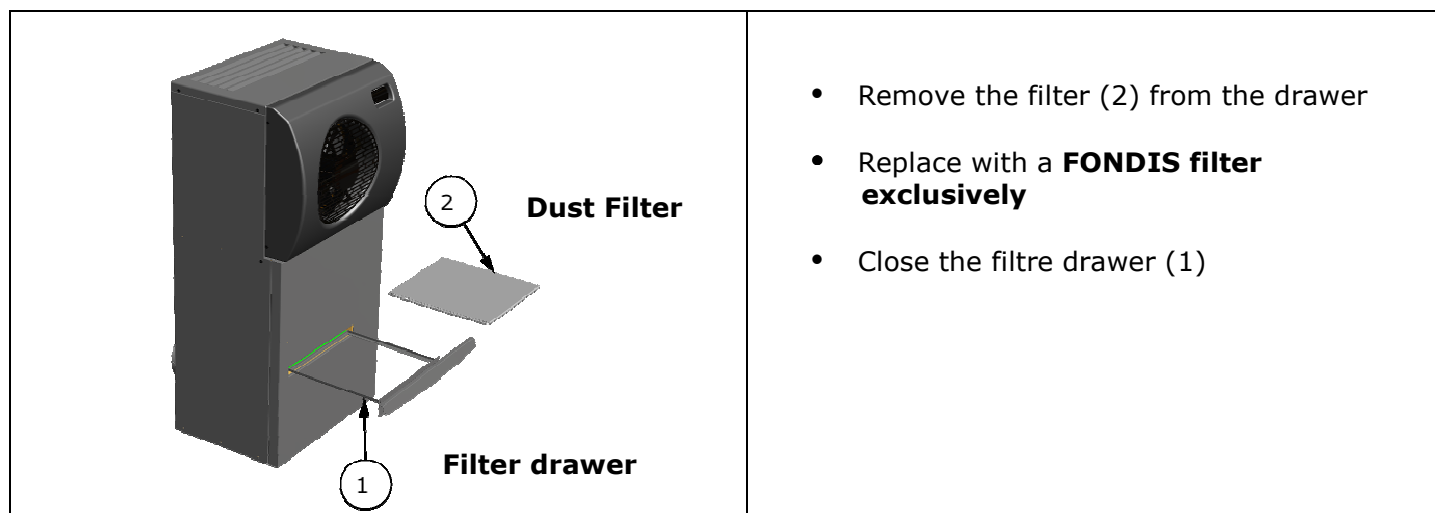

IMPORTANT :



- Regular filter cleaning (vacuum cleaner)
- Control : Every 3 month
- Replacement : Once a year
- SPOILED FILTER = DAMAGED WINE CONDITIONING UNIT

TO DO FOR OUTSIDE GRIDS :

- regular cleaning of outside grids (foliage...). Regarding the use

TO DO FOR THE DRAINAGE PIPE

- check if it is not blocked, clean if necessary.

5.2. Câblage du thermostat

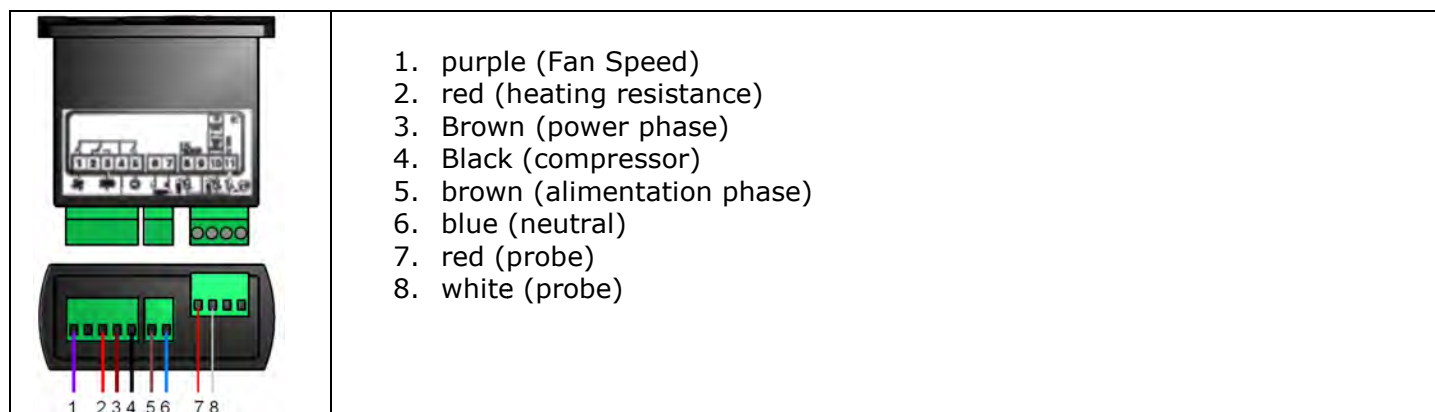

If you dismantled the sheet cover, tighten the ground screw (marked $\frac{1}{\text{E}}$) with a screwdrivers with a tightening torque of 1,5 N.m

6. WARRANTY

6.1. Legal warranty

The contractual warranty is not exclusive, the fundraiser for the purchaser profit of the legal warranty against latent defects that applies in terms of articles 1641 and following from the Civil Code.

6.2. 2 years contractual warranty

As a supplement to the legal warranty provided under the laws of the purchaser's country, FONDIS offers an additional **2 years** contractual warranty against any manufacturing defect.

During this period of contractual warranty, FONDIS will replace any parts that have a manufacturer's defect.

In case of electric failure, FONDIS reserves the right to send an expert technician to inspect the appliance before replacing any defective parts.

In case of refrigeration failure, FONDIS may require that the appliance is returned to the factory for repair. Any interventions will take place according to the guidelines set in the "after sale service" document.

Interventions and returns can only be done after written agreement from FONDIS after sale Service.

6.3. Warranty conditions

The contractual warranty applies to all appliances installed and used in conformity with this « User Manual ». Its application is conditioned by the presentation of the purchase invoice or for lack of its copy.

6.4. Exclusions and limitations of warranty

The warranty can be refused in following cases:

- Insulation of the cellar or installation of the appliance not in compliance with the instructions of this guide.
- Damage due to negligence, lack of maintenance or incorrect use of the WINEMASTER® (particularly dirty filters).
- Exchange or repair of parts under warranty will not extend the 2 years warranty period

FONDIS SA cannot, in any case, be held liable for any direct or indirect damages resulting from the failure of the air conditioner. The warranty is exclusively limited to the product itself provided by **FONDIS S.A.**



The European Community attaching a great importance to the environment and the waste processing, set up Directive 2002/96/CE relating to the Electric and Electronic Component waste.

In accordance with this standard, the logo "barred dust bin" is obligatory.

This logo means that this product cannot be thrown in the household shelter. It must be given to a suitable collection point for the treatment, valorisation, recycling of Electric and Electronic components.

Acting like that you make a gesture for the environment and you contribute to the safeguarding of the natural resources as well as to the protection of human health.